

Distributed Amplifiers in MMIC Technology based on Composite Right/Left-Handed Transmission Lines

Teresa M. Martín-Guero^{1*}, Diego Palombini², Francisco J. Mata-Contreras¹, Andrea Bentini², Francisco Y. Ng-Molina¹, Ernesto Limiti² and Carlos Camacho-Peñalosa¹

¹Departamento de Ingeniería de Comunicaciones. E.T.S. Ingeniería de Telecomunicación. Universidad de Málaga. Campus de Teatinos. 29071 Málaga, Spain

²Dipartimento di Ingegneria Elettronica. Università degli Studi di Roma 'Tor Vergata' Via del Politecnico no.1, 00133 Roma, Italy

Tel: +34 952133395; Fax: +34 952132027; E-mail: teresa@ic.uma.es

Abstract – Three MMIC distributed amplifiers based on Composite Right/Left-Handed Transmission Lines are presented in order to illustrate the actual performance of these devices, and the features that can be obtained with this distributed amplifier topology. Measurement results and/or qualified simulations have been included for two amplifiers with dual-band performance and for a high-power one. Also different frequency bands are illustrated, with examples at X-, C- and S-band operation.

Index Terms - Distributed Amplifier, CRLH Transmission Line, Diplexer, Dual-Band, Power Amplifier, Power Combiner.

I. INTRODUCTION

The use of Composite Right/Left-Handed Transmission Lines (CRLH-TLs) in the design of Distributed Amplifiers (DAs) has shown the feasibility of novel frequency responses, such as diplexer-type and optimal power combiner-type behaviors. The key to achieve these novel functionalities is the proper design of the actively coupled artificial transmission lines phase-constant [1-3]. DA topology is particularly appropriate for integrated realizations due to the possibility of embedding the input and output capacitances of the active devices into the artificial transmission line structures. At microwave frequencies additional advantages such as low losses and small size can be obtained if a MMIC technology is adopted for the implementation of such active distributed circuits.

In this contribution, three different realizations of DAs based on CRLH-TLs in monolithic technology are presented. Firstly, a DA fabricated in GaAs PHEMT technology is considered. The DA has achieved a dual-frequency response at X-band, showing more than 12 dB gain at both bands. Secondly, GaN devices have been used in the design of an active diplexer in C-Band that is presently under manufacturing. The expected gains are around 10 dB for both forward and reverse ports, and crosstalk levels are expected to be better than -20 dB. Finally, a pass-band DA for S-band has been designed. In this case the design target has been the optimal combination of the power delivered by three GaAs PHEMT devices. Simulated gain lies between 11 and 13 dB from 1.4 to 2.4 GHz, whereas output power is expected to reach 23 dBm, matching LTE specifications in this band.

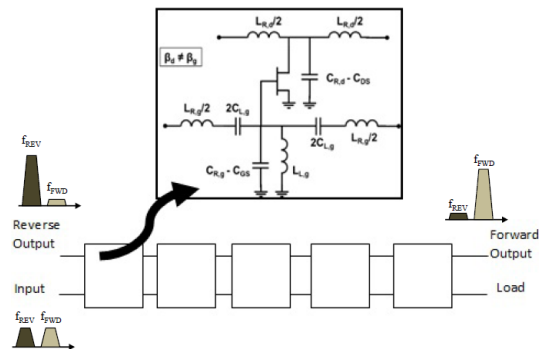

Fig.1. DA basic structure and operation

II. X-BAND DUAL FREQUENCY AMPLIFIER

An X-Band Distributed Amplifier that covers two of the Spanish satellite broadcast TV frequency bands has been built and measured. A schematic view of this structure is reproduced in Fig.1. With the use of CRLH-TLs in the gate line the wanted double frequency band response can be achieved. The topology of this distributed amplifier has an intrinsic diplexer capability, i.e., each band is driven through one different output port (forward and reverse output ports). The basic operation of the device is also illustrated in Fig.1.

It is worthy to mention that just one of the artificial lines, the gate line, has been designed as a pass-band structure, whilst the drain line is a conventional low-pass artificial TL. As it has been already shown in [3] it is possible to obtain dual band/diplexer response even in this case.

The topology of the artificial transmission lines employed in DAs is important when biasing the active devices. Band-pass transmission lines include inductors that generate a troublesome DC path if no additional consideration is incorporated in the design. To avoid such problems the CRLH-TL is used to connect the ‘unbiased’ gate terminal of the FET devices. Devices have been selected in order to offer the proper functionality (transconductance and capacitances values) even working at $V_{GS}=0$, avoiding the problems related with the DC source connection.

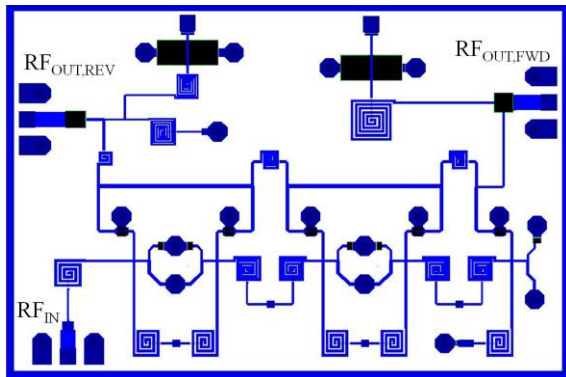

Fig.2. X-band amplifier photograph

The MMIC has been manufactured using the OMMIC D01PH process (0.15 μm , 4x45 μm GaAs PHEMT). Five stages are combined in a 3x2 mm² layout (see Fig. 2). Measurements for the first round samples fit well with the simulations performed during the design stage. Fig. 3 illustrates the prototype frequency response. The forward gain is around 12 dB in the lower pass-band (10.0-10.7 GHz) and the reverse gain is a bit lower in the upper pass-band (11.7- 12.5 GHz). It is noticeable that the forward band-pass is located at frequencies higher than the reverse band. Also, the widest band pass is always the upper one. These are intrinsic characteristics of the frequency response of DAs based on the combination of both RH-TL and CRLH-TL, as it has been demonstrated in [3].

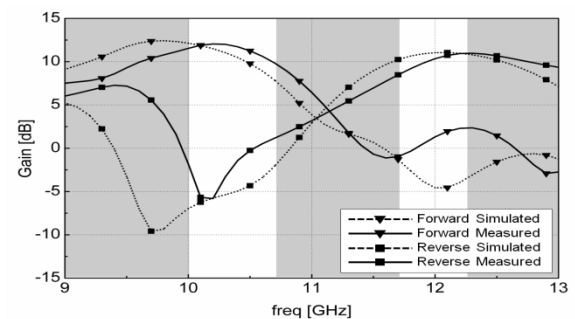

Fig.3. X- Band amplifier measured and simulated frequency response.

Measurements have confirmed also input and output return losses better than 9 dB for both bands. Also, noise figures below 9 dB have been measured for forward and reverse ports pass-bands.

Results demonstrate the viability of this approach. Specific aspects for monolithic technology such as the proper biasing of active devices have been solved and dual-frequency performance has been demonstrated for MMIC DAs.

III. C-BAND MMIC DIPLEXER

The use of monolithic GaN technology in the design of DA can increase the performance already demonstrated in the former prototype. GaN technology provides high power generation (considering the output level) and robust operation (low-noise receiver). For this reason a GaN MMIC diplexer has been designed for C-band operation [4]. The operation principle is that already presented in Fig. 1. The reverse gain profile is pass-band, from 5.5 to 6.5 GHz and the forward port has a 2 GHz pass-band, from 7.5 to 8.5 GHz. Specifications fulfill constraints imposed by the combination of conventional and pass-band artificial transmission lines. For this reason gate line has been designed as a CRLH-TL and the drain line is a conventional RH-TL.

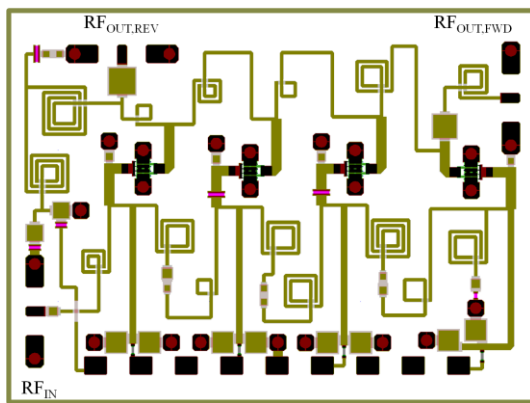

Fig.4. C-band amplifier lay-out design

Four GaN HEMT devices compose the active structure. The basic schematic layout is reproduced in Fig. 4. The total chip size is $3.5 \times 2.4 \text{ mm}^2$. Reported results are obtained considering active devices working at $V_{DS}=10 \text{ V}$ and $I_D=0.2 I_{DSS}$. Nevertheless, this design includes separated bias paths for each device in order to test the impact of different biasing profiles in the circuit final performance.

The structure has been simulated using AWR (circuit level) and AXIEM (electromagnetic level) and results are more than promising. Fig. 5 and Fig. 6 show the frequency response of the circuit. Fig. 5 shows the simulated gains (forward and reverse ports). The low crosstalk levels (below -

20 dB at central frequencies) between both output ports are remarkable. Fig. 6 includes the input matching information. The amplifier is expected to be matched (better than 15 dB) in the entire frequency band (5.5-8.5 GHz).

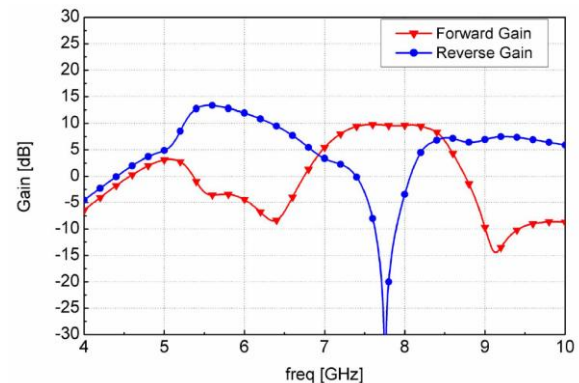

Fig.5. C-band amplifier expected gains

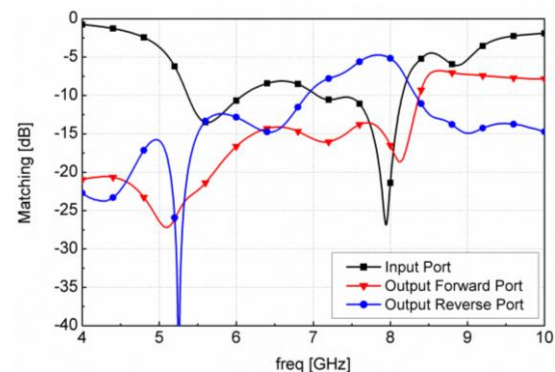

Fig.6. C-band amplifier expected input matching

According to the results already obtained for the X-band amplifier it is likely that the measurements of this C-band diplexer will confirm the expected frequency response. The amplifier is under manufacturing at SELEX SI Foundry Division.

IV. POWER DISTRIBUTED AMPLIFIER

The third design is a monolithic DA designed to cover the last stage of the LTE air interface (for some selected frequency bands). The pass-band is 1.3 GHz wide, centered at 1.9 GHz. P-HEMT

devices from ED02AH process by OMMIC have been employed. The layout is depicted in Fig. 7.

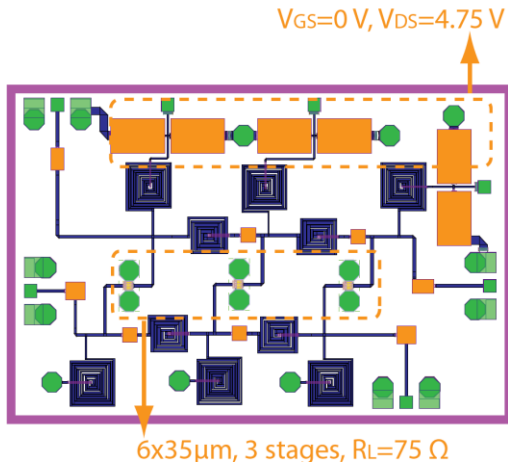

Fig.7. Power DA layout

The design consists of a three stage amplifier. Artificial transmission lines with 50 ohm characteristic impedance have been used. This results in load impedances for the active devices of 75 ohm. The bias condition of devices has been chosen to provide Class-A operation mode. In this case both lines are CRLH-TLs. Again gate bias can be set to 0V but $V_{DS}=4.75V$ requires decoupling capacitances at bias terminals.

This circuit is based on the principle described in [5]. The main idea is the optimum combination of the power delivered by all the transistors in the DA with are all working in Class-A mode, and are loaded with the corresponding matched load for maximum power delivering. These two conditions are fulfilled simultaneously for certain phase conditions in the artificial transmission lines (see details in [5]). Although the perfect condition is frequency dependent and it happens at just one frequency value, the dispersion law can be designed in order to get rather wide band performance. This has been done in the selected design and the final bandwidth achieved is greater than 60%.

Simulation of the circuit response has been performed in both large and small-signal regimes

and some results are summarized in next figures. Fig. 8 illustrates both output power and PAE @ 1dB compression point ($P_{in}=8.5$ dBm). Output power is over 23 dBm, covering LTE requirements. To confirm the suitability of the design for LTE applications, ACPR has been simulated for different radio interface conditions. Results are presented in Fig. 9. ACPR levels are always below the limits established by the standards.

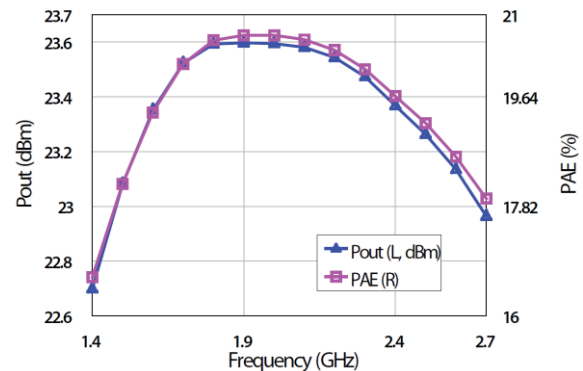

Fig.8. Simulated output power and PAE vs. frequency @ P_{1dB}

The circuit design is almost finished. It has passed the DRC (Design Ruler Checker) analysis before the submission to the foundry and, at present, is waiting for final tests to be performed by the MMIC manufacturer.

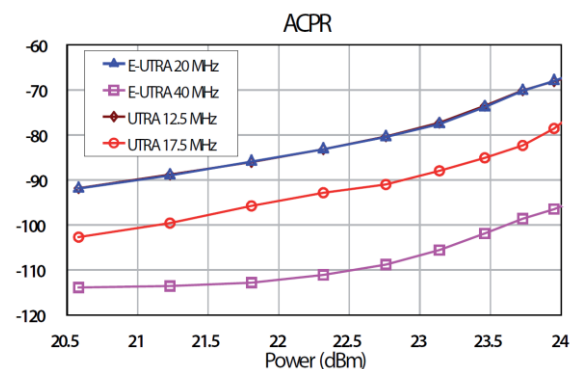

Fig.9. Simulated ACPR for different LTE modes as a function of output power



VI. CONCLUSION

Distributed amplifiers based on CRLH-TLs are feasible designs that can be implemented at microwave frequencies in MMIC technology. Three prototypes, at different design stages of development, have been presented in order to illustrate the basic performance offered by this approach. Good figures of merit, both simulated and measured, have been shown and confirm the interest of circuits based on this novel approach.

ACKNOWLEDGMENT

This work was supported by the Spanish Ministerio de Ciencia e Innovación (Programa Consolider-Ingenio 2010) under Grant CSD2008-00066 ('EMET'), and by the Junta de Andalucía (Spain) under Grant P10-TIC-6883.

REFERENCES

- [1] C. Xie, "Directional Dual Band Distributed power Amplifier with Composite Left/Right-handed Transmission Lines", IEEE MTT-S Int. Symposium Digest, Atlanta, USA, pp. 1135-1138, 15-20 June 2008.
- [2] K. Mori, T. Itoh, "Distributed amplifier with CRLH-transmission line leaky wave antenna", Proc. 38th European Microwave Conference, Amsterdam, The Netherlands, pp. 686-689, 27-31 October 2008.
- [3] J. Mata-Contreras, "Distributed amplifiers and mixers with transmission lines based on metamaterials," Ph.D. Thesis, Univ. Málaga, Spain, 2010.
- [4] J. Mata-Contreras, D. Palombini, T.M. Martín-Guerrero, A. Bentini, C. Camacho-Peñalosa and E. Limiti, "Active GaN MMIC diplexer based on distributed amplification concept", Microwave and Optical Technology Letters, vol. 55, pp. 1041-1045, May 2013.
- [5] F. Y. Ng-Molina, T. M. Martin-Guerrero, and C. Camacho-Peñalosa, "Power and gain considerations in distributed amplifiers based on composite right/left-handed transmission lines", IET Microw., Antennas, Propag., 2010, vol. 4, pp. 1000-1006.